



Printable Fit Template for OXA SpikePods

1. Cut along the red lines. 
2. Fold along the center line. 
3. Cut along the black lines. 
4. Fold open.
5. Place the template on the stock at the installation point (behind the sling stud).
6. If the rifle stock do not fit within the 45 mm opening, choose the larger model: Hunter L.

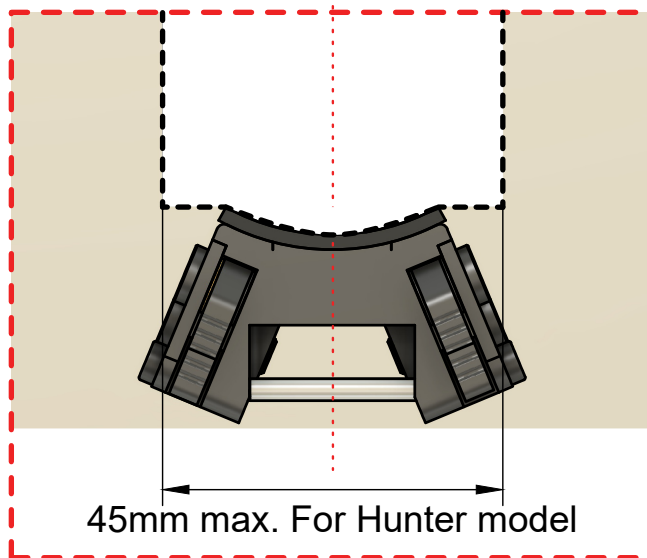

OXA Innovations
www.oxainnovations.com
info@oxainnovations.com
Tel +358 44 989 4360

Hunter model is suitable for stocks up to 45 mm wide.

If your rifle stock is wider (at the installation point), please choose the Hunter L model, which is suitable for stocks wider than 43mm

IMPORTANT: Print at 100% scale. Do not use “Fit to page”. Scale 1:1 (Actual size)

NOTE: The bottom curvature does not need to be exact. OXA also fits flat-bottomed stocks.

If you need any assistance to ensure proper fitting and/or choosing the right model, please do not hesitate to contact us directly.

Installation Placement for Hunter and Hunter L

(not in 1:1 scale)



Reccomented Sling stud distance from stock front end:
Minimum: 4 cm
Optimal: 7–9 cm

Notice: Sling stud relocation is usually a minor operation if required. If your stock does not have a sling stud on the underside, one can generally be installed relatively easily. However, we recommend having all stock modifications performed by a qualified gunsmith.

Notice 2: OXA Hunter and Hunter L can also be installed on M-LOK, Picatinny, and Anschütz rails, as well as on QD sling sockets, when used with the appropriate adapters. Detailed information about compatible adapters is available on our website.



In stocks with a schnabel forend, the sling stud should be at least 4 cm from the point where the schnabel starts to curve.

